

Meta-conversational *since when*-questions and the common ground

Angelika Kiss

University of Toronto, Department of Linguistics

angelika.kiss@mail.utoronto.ca

Abstract

This paper presents some novel properties of the so-called Negative Wh-Construction. It is argued here that not all wh-phrases participating in the construction can be analyzed the same. Namely, *since when*-questions can target some aspect of the previous speech act, and not necessarily the propositional content conveyed by it, as opposed to Negative Wh-Constructions with *where*. It is proposed that *since when*-questions operate on a meta-conversational level, expressing a question about the common ground.

1 Introduction: The Negative Wh-Construction

The Negative Wh-Construction (NWHC) is a special question type: by its form it is a wh-interrogative, but it serves as a denial to some previous utterance.

- (1) A: John is a vegetarian.
B: Since when is John a vegetarian?

Since when in B's reaction bears emphatic stress and the utterance expresses that B does not believe the proposition 'John is a vegetarian'. Wh-questions expressing such a denial have been observed in a variety of unrelated languages, such as Malay, Gungbe, Hebrew, Slovenian, Kannada and Bengali, among others (Cheung, 2008).

Languages differ in the subset of wh-words they allow to participate in a NWHC, and besides *since when*, counterparts of *where*, *when* and *how*, among others, have been attested. The following are Cheung's examples.

- (2) a. Cantonese

Koei bindou jau hai toushugun sik
he where have be.at library eat
je aa3?!
thing Q

'No way did he eat anything in the library.'

- b. Korean

{Eti/Ettehkey} John-i 60 sal
{where/how} John-NOM 60 year.old
i-ni?!
be-Q

'No way is John 60 years old.'

- c. Spanish

De dónde va a tener 60 años?!
of where goes to have 60 years

'No way is he 60 years old.'

(Cheung, 2009, p. 298)

The wh-words in NWHCs have been analyzed as "surrogates" for conversational backgrounds.

- (3) What is the proposition q such that in view of q, p ? (Cheung, 2009, p. 313)

By uttering a NWHC, the set of propositions q ranges over a set of propositions contextually relevant to or compatible with the evaluation world w . This interpretation makes NWHCs equivalent to descriptive negation (Horn, 1985), thus the at-issue meaning of *since when p?* is $\neg p$. Crucially, Cheung claims that there is no difference between NWHCs using different wh-words, they all are interpreted the same way. The at-issue meaning is accompanied by two conversational implicatures, the Conflicting View Condition (Speaker believes that Addressee holds an opposing view) and the Mis-Conclusion Condition (Speaker believes that Addressee has come to the wrong conclusion) (Cheung, 2009).

This paper challenges Cheung's analysis: *since when*-questions, at least in the languages looked

at, behave differently from *where*-questions, as they do not necessarily express a propositional negation but seem to express a meta-conversational move instead.

Example (4) challenges Cheung's analysis which would predict that (4B) convey the proposition 'you don't use the tu-form with me', which is far from reality.

- (4) A: [utterance in tu-form]
B: Ma da quando mi dai del tu? (Italian)
'Since when do you use the tu-form with me?'

NWHCs with *since when* have uses that do not involve negation but express merely surprise or disapproval. Also, *since when*-questions can target enthymemes more readily than NWHCs with *where*, in languages that can use both question words in NWHCs. These two uses suggest that instead of a propositional negation analysis, it is more advantageous to assume that by a *since when*-question, the Speaker asks for further evidence before grounding the proposition under discussion.

The present paper argues for the following: *since when*-questions differ from *where*-questions, contrarily to what Cheung claims, and a NWHC with *since when* expresses a question about the common ground, asking 'Since when is it part of our common ground that *p*?'. Section 2 presents supporting arguments for the claim that *since when*-questions are meta-conversational moves, in section 3, the context is defined and the denotation of *since when* is given, in section 4, *since when*- and *where*-questions are compared in terms of commitments, section 5 presents typical follow-ups, and section 6, the conclusion.

2 Meta-conversational *since when*

The present paper argues for the idea that *since when*-questions are actually questions *about* the common ground, which is not incompatible with how Buring views *since when*-questions or as he calls them, "*since when*-attacks" (Buring, 2012). Thus (1B) can be paraphrased as follows: 'Since when is it part of our common ground that John is a vegetarian?' Such moves initiate a revision of the common ground of the interlocutors because of a mismatch in the interlocutors' dialogue gameboards, which are their version of the common ground (Ginzburg, 2012).

Ginzburg (1997) calls our attention to the fact that any utterance, like other spatio-temporally located entities, can be the object of description or wondering. Furthermore, dialogues are in large part made up of activities that actually relate to the conversation itself, an example of which is clarification. His observations support the picture of NWHCs with *since when* presented here and the idea of them being meta-conversational moves.

Also, speakers of different languages have reported that *since when*-questions do not necessarily express a full rejection of the proposition expressed by the preceding utterance. That is, a *since when*-question signals that the proffered proposition cannot be accepted into the common ground as it is, in other words, it cannot be grounded (Clark, 1996), until more evidence is provided. This intuition seems right in light of the facts presented in the following subsections.

2.1 Special uses of *since when*

There are at least two uses of *since when* that do not fit into the picture Cheung gives about the NWHC.

2.1.1 Targeting enthymemes

Consider the following examples. In neither of them does the *since when*-question directly reject the proposition *p* expressed by A's utterance, but something that is contextually entailed by it, *q*: 'sources are always reliable' or 'John likes studying, because he started a university program', respectively.

- (5) CR: ...and there are scurrilous rumors about many members, mainly spread by this man who publishes this magazine Hustler. No one wants to use him as a reliable source, heaven knows, but it's got members very concerned.
PJ: Since when, in this particular year, were sources always necessarily reliable? (COCA 19991212)¹
- (6) A: John has started a university program.
B: Since when does John like studying?

In both examples, the reacting move does not express propositional or descriptive negation of the proposition expressed by the latest move; rather, it challenges or negates the enthymeme,

¹Corpus of Contemporary American English, www.corpus.byu.edu

and thereby is a request to provide more evidence so that *p* could be grounded.

B's response in (6) exemplifies a case in which the interlocutors rely on the notion of *enthymemes*, which are arguments that are not spelled out in a discourse but on which discourse participants can rely on to make sense of the conversational moves. Aristotle pointed out the importance of building on common beliefs and opinions when addressing a crowd, a point that has been brought to our attention again in recent works on the micro-rhetorical analysis of dialogues (Breitholtz and Cooper, 2011; Breitholtz, 2014). The interlocutors understand (7a) because they rely on the enthymeme (7b).

- (7) a. Oh! I'm invited to a wedding that night. But the bride is pregnant so I might drop by in the wee hours!
 b. Because the bride is pregnant, the speaker will be able to drop by the birthday party. (Breitholtz, 2014)

The enthymemes targeted by *since when*-questions are thus considered true by CR in (5) and A in (6) but false by the utterer of the *since when*-question. Targeting enthymemes is not a unique property of meta-conversational *since when*-questions, *why*-questions can also do so (Schlöder et al., 2016), just as polar questions and rising declaratives.

What is important here is that *since when*-questions differ from *where*-questions as they can more readily target enthymemes than NWHCs with *where*, which is shown by languages that use both *since when* and *where*, like Hungarian and Italian.

- (8) A: John has started a university program.
 B's reply:
 a. Hungarian
 Mióta szeret John tanulni?
 since-when likes John studying
 'Since when does John like studying?'
 b. #Hol szeret John tanulni?
 where likes John learn
 Lit.: 'Where does John like studying?'
 c. Italian
 Da quando John ama studiare?
 since when John likes studying
 'Since when does John like studying?'

- d. #Ma dove John ama studiare?
 but where John likes studying
 Lit.: 'Where does John like studying?'

NWHCs with *where* seem to have an echo-condition, and so they are more restricted in what they can target. Both *where* and *since when* can express a descriptive negation of the proposition expressed by the latest move, but *since when* allows for a weaker rejection by questioning the enthymeme on which that proposition is based. Cheung's analysis leaves no room for that.

2.1.2 Targeting the register

Another use of NWHCs with *since when* that does not echo and negate the proposition expressed by the latest move is the one that targets the register of the previous utterance. The examples in (9) are uttered by a Speaker who was addressed in the tu-form instead of the vous-form, a fact that made him upset. B's utterance expresses a scold, and could be paraphrased as 'you should not use the tu-form with me'.

- (9) A: [utterance in tu-form]
 B's reaction:
 a. Mióta tegezel? (Hungarian)
 b. Ma da quando mi dai del tu? (Italian)
 c. Enjey-pwuthe neka nahanthey pan-malhani? (Korean)
 d. S kakix eto por chto vy obrash'aetes' so mnoj na ty?
 'Since when are you using the tu-form (informal style) with me?'

Such utterances do not fit into Cheung's picture of NWHCs either. The way he represents the meaning of NWHCs, they have to reject the propositional content of the previous utterance; however it looks like different aspects of an utterance can be targeted. These scolding NWHCs need the same discourse-related conditions in order to be felicitously used: there should be a previous utterance, thus they cannot be uttered out of the blue, the Speaker's and Addressee's views on the issue should be in conflict and Speaker must think that the Addressee is wrong. The difference is that instead of the issue being the truth of a proposition *p*, in this case it is the register of the utterance.

Crucially, not all wh-words that can be used in NWHCs can target the register of the previous utterance directly, in the languages looked at, it looks like *where* cannot do the same.

- (10) a. Te hol tegezel? (Hungarian)
you where use.tu.form
- b. Ne eti-ka na-hanthey
you where-NOM I-to
panmalha-ni? (Korean)
use.tu.form-Q
'Where are you using the tu-form (in-
formal style) with me?'

B's utterance in (10) could only receive an interpretation of 'you don't use the tu-form with me', and such an utterance would only be felicitous if A's utterance expressed the proposition 'I use the tu-form with you'. In this case, however, the denial happens no longer on the meta-conversational level of register but on the propositional level. NWHCs with *since when* have no such requirements on the propositional content of the preceding utterance that they target. Such moves can also be made by *why*-questions (Schlöder et al., 2016), polar questions and rising declaratives.

In sum, these two special uses show that meta-conversational *since when*-questions, as opposed to *where*-questions, express a move that is weaker than rejection, a move that is closer to conversational backoff (Rawlins, 2010), which can happen at a propositional level, questioning the truth of the enthymeme under discussion, or at a non-propositional level, targeting the register of the preceding utterance.

2.2 Syntactic markedness

The claim that *since when*-questions are meta-conversational moves gets further support from facts about the syntax of NWHCs. Most of these facts have also been observed by Cheung, although he used them to support his propositional negation analysis. Here, these observations are used as arguments for the claim that *since when*-questions are meta-conversational moves.

2.2.1 Cooccurring answers

The constituent that in a genuine question would serve as an answer to the *wh*-phrase can cooccur in the same question, as in (11), a property observed by Cheung.

- (11) Since when has he been working at UCLA
since 2000? (Cheung, 2009, (8))

2.2.2 Temporal properties of the predicate

Another similar property comes from the unexpected compatibility can be observed between the

temporal properties of the event predicate in the *wh*-phrase.

(12) Italian

Da quando ha deciso di votare per lui?
since when has decided to vote for him

Lit.: 'Since when did he decide to vote for him?'

(13) Russian

S kakix por ty stala l'ubit'el'nicej
since when you became fan
xokkeja?
of.hockey

'Since when did you become a hockey fan?' (RNC)²

Neither *decide to vote for him* nor *become a fan of hockey* can be modified by timespan adverbials, which is why *since when*, in a genuine question, cannot be used with these predicates. Yet what we see is that in a NWHC with *since when*, they do not make the sentence ungrammatical.

2.2.3 Syntactic restrictions

If NWHCs having *since when* are questions asked about the common ground, we expect that they pertain to the realm of discourse-related syntactic projections in the left periphery. Indeed, this is what we find in the case of NWHCs, as it has also been observed by Cheung (2008): even *wh*-in-situ languages allow less positions for *wh*-phrases in NWHCs than in genuine questions, and the allowed positions are always the leftmost ones. Also, discourse-related syntactic projections are high enough not to be able to embed, and this property also seems to hold of NWHCs in general and cross-linguistically (Cheung, 2008).

2.3 Summary

In sum, *since when* expresses a question about the common ground, because the Speaker of it has reason to believe they have opposing beliefs on the proposition in question. This proposition, however, need not be the one expressed by the latest move, it can be one that serves as an enthymeme in it, or it can be a non-propositional aspect of that utterance, such as its register. The claim that *since when* does not operate on the propositional level, and so it is a non-canonical question, is supported by the fact that it is syntactically marked.

²Russian National Corpus, www.ruscorpora.ru

3 The semantics of *since when*

The way Farkas and Roelofsen (2017) define the context is a suitable starting point for the context relevant for NWHCs: it consists of a set of participants, of the table, containing all the raised and yet unresolved issues (Farkas and Bruce, 2010), and the set of commitments, mapping each participant to all propositions they are publicly committed to.

- (14) Model of context:
 ⟨participants, table, commitments⟩
 (Farkas and Roelofsen, 2017)

Ginzburg calls our attention to the fact that utterances do not only contribute propositional content to the common ground, but different aspects (if noted by the interlocutors) could also become part of it, even formal properties such as phonology or word order. Whenever the common ground is updated with a proposition, it is also updated with the meta-level properties of the utterance that conveyed that proposition. He dubs this phenomenon the ‘rich but graded update’ of the common ground (Ginzburg, 2012, p. 27). By assumption, these metacommunicative properties come in the form of propositions. Thus, upon grounding a proposition conveyed by an utterance in a dialogue, the common ground gets updated with the propositional content, but also with propositions about the syntactic form, the style, the phonological form, the time and place of the utterance, and the time of its grounding.

Ginzburg’s insight on the ‘rich but graded update of the common ground’ is relevant because it grasps the difference between NWHCs with *where* and *since when*. While *where*-NWHCs target the propositional content of the latest move, that is, of an issue that is on the table, and they negate it, *since when*-NWHCs can target any proposition relating to p that in case of grounding p would be added to the common ground.

Each conversation can be described as a sequence of states of the common ground, and these states can be located in time. Each change made on the common ground, the addition or elimination of a proposition, can be associated with a timepoint, so common ground states can be mapped onto a timeline, an idea in line with how Ginzburg (2012) pictures the dialogue, namely as having step-by-step representations of momentary belief-sets, as many at a time as many discourse participants there are, a representation similar to

the representation of a chess game.

Since when, in its literal sense ranges over times: the idea is that in its meta-conversational use as a NWHC, it could target the timeline of the developing common ground. Each grounded proposition $g(p)$ is associated with a meta-level proposition ‘ $g(p)$ was grounded at t ’. Assuming that *since when* has such a meta-discursive function, it could be paraphrased as indicated:

- (15) ‘Since when is it (or should it have been) part of our common ground that p ?’

A NWHC with *since when* looks for the proposition q such that it expresses that p was grounded at time t if p was in the common ground.

- (16) $\llbracket \text{since when } p \rrbracket =$
 $\{q: \exists t \in T_{AB} \text{ s.t. } q = \hat{(t = \tau(g(p)))}\}$

Regardless of whether a proposition p has entered the common ground as an issue from the table that got resolved or as a meta-discursive proposition that was never pronounced, if it is part of the common ground, it must have been grounded ($g(p)$) and so it can be mapped onto the timeline T_{AB} by the function τ .

When a *since when*-question targets an enthymeme, the time is searched for, when the enthymeme q was grounded. The case when *since when* targets the register of the previous utterance, the Hamblin-set will consist of propositions that are grounded in the interlocutors’ common ground and express that B allows A to use the tu-form. This is shown by an Italian example, a language that has the tu/vous distinction.

- (17) p : Ti ho chiamato ieri.
 ‘I called you yesterday’
 a. q_1 : p is uttered in a café
 b. q_2 : p is uttered in Italian
 c. q_3 : p is uttered in the tu-form
 d. etc.

Before grounding it, the Addressee considers p and the set of propositions q expressing meta-discursive properties of the utterance conveying p . The event of allowing someone to use the tu-form at a time t preceding the utterance time should be present in the common ground as a proposition, belonging to an earlier stratum of the common ground (Clark, 1996). The Speaker of the *since when*-question believes this is not the case. In this case, the truth of p itself is not threatened

at all. However, by (9b, a new subinquiry is initiated about q_3 , the time of the grounding of the event that licenses the use of the tu-form, so that it becomes the latest move, taking priority over any question under discussion brought up previously (Farkas and Bruce, 2010; Roberts, 2012).

In sum, NWHCs with *since when* differ from NWHCs with *where* in that they can target a different set of propositions: *where*-questions target a proposition from the table, but *since when*-questions are not restricted to the table. Also, *where*-questions express propositional negation while *since when*-questions ask about the time of the grounding event of the proposition under discussion.

4 A speech act on the common ground

The proposal to defend in this paper is thus the following: *since when*-questions are marked moves that can target some aspect of the speech act that precedes them (the latest move) in the conversation. Similarly to metalinguistic negation utterances, this can happen “on any grounds whatever” (Horn, 1985). Since discourse participants can talk about the common ground, they can also talk about non-propositional aspects of the utterances it is built up of, an example of this is acknowledgement, by which the Addressee signals that she has noticed the speech act and possibly the content conveyed by it (Ginzburg, 2012).

Since when-questions initiate a revision of the common ground. Such a move needs a good enough reason, according to the following principle:

- (18) Principle of Economy
Do not use a meta-conversational move unless necessary (to resolve epistemic conflict or to ensure Quality).
(Romero and Han, 2004, p. 629)

Cheung’s formulation of the discourse-related constraints of using NWHCs (the Conflicting View Condition and the Mis-Conclusion Condition) describe a situation in which the discourse participants have opposing beliefs: this is exactly a case that the Principle of Economy lets through.

4.1 NWHCs in terms of commitments

Any utterance expressing the proposition p represents a proposal made to the other interlocutors to assume p into their common ground. The proposal

nature of assertions has been emphasized by many (Clark, 1996; Farkas and Bruce, 2010; Roberts, 2012; Ginzburg, 1997). At the same time, an assertion commits its Speaker to the truth of the proposition in question (Gunlogson, 2001; Krifka, 2017).

Krifka (2017) offers an analysis of speech acts that makes reference to commitment states. In his view, speech acts create commitments that get associated with interlocutors of the discourse, and each stage of a conversation can be represented by a current commitment state c , which is the set of commitments associated with the interlocutors. Speech acts are thus functions from commitment states to commitment states. An assertion commits its Speaker to its truth so that the Speaker can be held accountable for it as long as she does not change her commitment. But this is not the only move an assertion makes; an assertion also invites the Addressee to integrate the proposition p expressed by that assertion into the common ground. The two moves can be represented as follows:

- (19) a. $[S:p]$ = Speaker S commits to proposition p
b. $[p \in cg]$ = Proposition p is to be admitted into the common ground cg
(After Krifka 2017)

Every commitment state is associated with the corresponding state of the common ground. To model admissible continuations of commitment states, Krifka uses the notion of commitment space. A commitment space is a set of commitment states that originate from the same root commitment state \sqrt{C} . These commitment states in the commitment space are all possible continuations of the root commitment state.

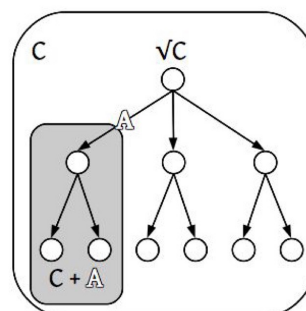

Table 1: Update of commitment space C with speech act A (Krifka 2017, Fig. 2)

4.1.1 *Since when* in the commitment space

There are three components in play in a *since when*-question: the non-acceptance of the latest move, a request from the Speaker to provide evidence for p so that it could become grounded and thirdly, the expression of doubt that the Addressee will manage to come up with such evidence.

- (20) *Since when* expresses
- the non-acceptance of the latest move, [p ∈ cg]
 - a request for evidence that p is part of cg
 - the Speaker's doubt about Addressee's providing that evidence

As for the first component, non-acceptance of p , it is expressed by the lack of an acceptance move by the Speaker of the *since when*-question, $ACCEPT_S(p)$. The non-acceptance of the speech act itself does not imply the rejection of the propositional content contributed by it. However, there is room for the proposition itself to be rejected by such a move as well.

As for the second component of the meaning of meta-conversational *since when*, the operator REQUEST could be used, which requests commitments from discourse participants. Krifka demonstrates its use with Rising Declaratives, which, according to Gunlogson (2001), are assertions with a rising boundary tone expressing that the Speaker attributes a commitment to the Addressee. By the Rising Declarative 'Shoplifting's fun?', S invites A to commit himself to the proposition 'shoplifting is fun' by updating the latest commitment space with a commitment state that contains this speech act.

Although a *since when*-question expresses a request as well, instead of REQUEST, its special version, I-REQUEST is used. Beside the function of a regular REQUEST operator, I(mplicature)-REQUEST also conveys the conventional implicature consisting of the Speaker's doubt that the Addressee will be able to come up with a congruent answer.

Krifka shows its use by a Negated Polarity Question that has an incredulous intonation.

- (21) Isn't there a vegetarian restaurant around here?!
- $$\langle \dots, C \rangle + I-REQUEST_{S,A} (ASSERT_{A,S} ('there is a vegetarian restaurant around$$

$$\text{here}') =$$

$$= \langle \dots, C \rangle + \neg ASSERT_{A,S} ('there is a vegetarian restaurant around here') =$$

$$= \langle \dots, C \rangle + \neg [A:p]$$

Following (Krifka, 2017, (62))

The I-REQUEST operator hosts the Speaker's negative bias towards p as a conventional implicature. At the same time, I-REQUEST still requests a move from the Addressee by to further commit himself to p by presenting evidence for p , namely to tell when p was grounded. The content of I-REQUEST is conveyed by prosodic means. I-REQUEST carries both the second and the third meaning components of what *since when* expresses, (20b) and (20c).

I argue that just like in (21), where the incredulous intonation marks the conventional implicature of the Speaker's disbelief, a NWHC introduces the same conventional implicature by the tune with a falling contour and by the emphatic stress on the wh-phrase. It has been shown that intonation and stress properties can influence the interpretation of sentences in significant ways, even if no one-to-one correspondence can be established between prosody and meaning (Gunlogson, 2001; Asher and Reese, 2007; Krifka, 2017; Pierrehumbert and Hirschberg, 1990; Banuazizi and Creswell, 1999).

A NWHC with *since when* thus expresses the following:

- (22) *Since when* is John a vegetarian?
- $$\langle \dots, C \rangle + I-REQUEST_{S,A} (ASSERT_{A,S} (\text{the time } t \text{ such that 'John is a vegetarian' is grounded}))$$
- $$= \langle \dots, C \rangle + \neg ASSERT_{A,S} (t \text{ such that 'John is a vegetarian' is grounded in } t)$$
- $$= \langle \dots, C \rangle + \neg [A: t \text{ such that 'John is a vegetarian' is grounded}]$$

In words, what happens upon uttering a *since when*-question is that the Speaker does not accept the latest move, which is an invitation to the interlocutors to admit *that John is a vegetarian* into the common ground. This is shown by the lack of any acceptance moves. Also, by the phonological properties mentioned above, the *since when*-question becomes even more marked. Recall that *since when*-questions are marked already as far as their syntactic properties are concerned. Signalling non-acceptance of a previous assertion is expected to be marked (Farkas and Bruce, 2010; Farkas and Roelofsen, 2017).

Since when asks for a time t pertaining to the timeline of the common ground such that *John is a vegetarian* is grounded in t . In other words: the Speaker expresses the question: ‘When did we agree that *John is a vegetarian* became part of our common ground?’. From the question, the interlocutor can infer that it is not part of the common ground, because if it were, the question would not arise. Also, the boundary tone L% and the emphatic stress on the wh-phrase contributes the conventional implicature conveying that the Speaker does not believe the proposition in question is true, so it conveys that the Addressee will not be able to present a congruent answer to her question³.

By the move I-REQUEST, the role of intonation is included in the representation of *since when*’s function. Although the present study did not aim to characterize the prosody of NWHCs, some phonological properties are salient enough to be considered as cues on which other interlocutors can rely on. These properties include the emphatic stress on the wh-phrase and the falling intonation or low boundary tone. The Speaker makes use of intonation to convey “how S[peaker] intends that H[earer] interpret an intonational phrase with respect to 1) what H already believes to be mutually believed and 2) what S intends to make mutually believed as a result of subsequent utterances” (Pierrehumbert and Hirschberg, 1990).

4.1.2 *Where* in the commitment space

Unlike *since when*, NWHCs with *where* actually reject the latest move $[p \in \text{cg}]$, and they also seem to add the commitment $[S:\neg p]$ and $[\neg p \in \text{cg}]$, which reflects Cheung’s description of NWHCs as expressing descriptive negation. Cheung’s description of NWHCs corresponds to adding the elements $[S:\neg p]$ and $[\neg p \in \text{cg}]$. This difference can explain why *since when* but not *where* can target different aspects of an utterance and not necessarily the proposition expressed by it. As a NWHC with *where* expresses a rejection of the latest move, commits its Speaker to $\neg p$ and adds the invitation to admit $\neg p$ to the common ground, the corresponding commitment state will contain $\neg p$. This is in conflict with the interlocutor’s belief p , that causes a crisis in the conversation (Farkas and

³Whether a proposition is true and whether it is part of the common ground are not the same thing; but by assumption, if an interlocutor does not consider a proposition as part of the common ground, it is because that proposition is not considered true.

Bruce, 2010).

NWHCs with *since when* are moves of common ground management (Krifka, 2008), that is, they do not change the common ground (they do not add factual information to it) but merely impose restrictions on the interlocutors on the future continuations of the conversation. NWHCs with *where* do change the common ground as they do add new commitments.

To illustrate what a NWHC with *where* does, a Korean example is used, as ‘where’ in English does not participate in NWHCs.

- (23) Korean
- a. A: John is 60 years old.
 - b. B: Eti John-i 60 sal i-ni?!
B: where John-NOM 60 year.old be-Q
‘No way is John 60 years old.’

The contribution of the assertion expressed by (23a) updates the commitment space as follows:

$$(24) \langle \dots, C \rangle + \text{ASSERT}_{S,A} (p: \text{‘John is 60’}) = \\ = \langle \dots, C + [S:p], C + [S:p] + [p \in \text{cg}] \rangle = \\ = \langle \dots, C, \{c \in C \mid \sqrt{C} \cup \{[S:p]\} \subseteq c\}, \\ \{c \in C \mid \sqrt{C} \cup \{[S:p]\} \cup \{[p \in \text{cg}]\} \subseteq c\} \rangle \quad (\text{Krifka, 2017, (21)})$$

The following move, the *where*-question, rejects the latest move of this update, namely the invitation to admit p into the common ground. The move immediately preceding that, S committing herself to the truth of p is not rejected by A. C in (25) equals the resulting commitment space of (24), $\{c \in C \mid \sqrt{C} \cup \{[S:p]\} \cup \{[p \in \text{cg}]\} \subseteq c\}$.

$$(25) \text{“Where is John 60 years old?” (=23b)} \\ \langle \dots, C \rangle + \text{REJECT}_{S,A} [p \in \text{cg}] + \\ + \text{ASSERT}_{S,A} (\neg p: \text{‘John is not 60’}) \\ = \langle \dots, C + [S:\neg p], C + [S:\neg p] + [\neg p \in \text{cg}] \rangle \\ = \langle \dots, C, \{c \in C \mid \sqrt{C} \cup \{[S:\neg p]\} \subseteq c\}, \\ \{c \in C \mid \sqrt{C} \cup \{[S:\neg p]\} \cup \{[\neg p \in \text{cg}]\} \subseteq c\} \rangle$$

By (25), there are now two opposing commitments present in the commitment space. The first speaker added her commitment for the truth of p , and the second speaker committed himself for $\neg p$: this creates a crisis in conversation, as expected. Because of REJECT and ASSERT present in the *where*-question, there is no room for any kind of denial that does not happen on the propositional level.

Since when questions, I argue, do not contain the assertion component, and there is also no invitation to integrate any proposition to the common ground, as it is shown in (22). What *since when* does is to ask for a time t such that the proposition under discussion was grounded at t , with the conventional implicature of not believing that the Addressee will manage to do so. The commitment $\neg[A: t \text{ such that } p \text{ is grounded}]$ does not directly concern the proposition, it only concerns its grounding, or in other words, its assertability.

5 Answers and follow-up

The Addressee, being challenged by the *since when*-question, can either surrender or defend his position by providing evidence. What we find is that *since when*-questions are followed by a proposition which either supports p or $\neg p$.

- (26) C1: But I love Barbies
 H1: You love Barbies. Since when do you like Barbie dolls?
 C2: I love Barbies. They're my only (inaudible).
 H2: Oh no. You've got to be kidding me. You're definitely not getting a Barbie doll.
 (COCA 121216)

It seems that there has been a mismatch between the two versions of the common ground between C and H, because of the opposing beliefs about the proposition 'C likes Barbies'. This issue has been resolved so that both interlocutors believe the proposition under discussion to be true, the Speaker of the *since when*-question has thus surrendered: he was given some evidence so that he can ground the proposition under discussion.

In some cases, a *since when*-question can be ambiguous between its canonical and meta-conversational readings. The stative predicate *be illegal* can be located in time, so an actual information-seeking *since when*-question can target it.

- (27) C: -well, we were taking a picture from outside the gate, shooting into the university, and we were told that that is illegal
 K: Since when?
 C: This is a brand new thing. There's no codified law like this. (COCA 19900601)

The answer C gives to the question is still compatible with both the information-seeking and the meta-discursive use of *since when*.

The corpus contains examples of NWHCs used as Rhetorical Questions in that they suggest an answer that is assumed to be shared and obvious. They can be answered, but they need not be (Caponigro and Sprouse, 2007). In the excerpt (28), the Speaker does not disagree with her audience, rather, she uses the *since when*-question to underline her argument and to contradict the views of some third party.

- (28) B: Give me one tough as a cast iron skillet with a bumper that's extra large and a hood that's weighs over 85 pounds and looks like prow on a barge. I like style, but since when should a truck be touted for "comfort" and "ride". Power windows? On pickups? Remind me of jeans with a zipper that zips up the side.
 (COCA 20010224)

What is seen from the follow-ups is that they provide a proposition that serves as a support for their original claim that has been challenged by the *since when*-question. This property is captured by the I-REQUEST operator in section 4.1.1 which asks for evidence.

6 Conclusion

In this paper, I have argued that all NWHCs do not behave alike. *Since when*-questions express a move that does less than a full rejection of the proposition expressed by the latest move. *Since when*-questions are asked about the common ground, expressing the question 'Since when is (or should have been) the proposition p in our common ground?' NWHCs with *since when*, as opposed to NWHCs with *where* do not contain the operators REJECT and ASSERT, which explains why they can target other aspects of the preceding speech act.

Acknowledgments

I owe many thanks to Michela Ippolito, Guillaume Thomas, Elizabeth Cowper, Lisa Cheng and Donka F. Farkas for their valuable comments, as well as to the audience of the 10th Toronto-Ottawa-Montreal Semantics Workshop. I also thank my linguistic consultants: Julie Doner, Alexei Kochetov, Jessica Mathie, Dan Milway, Giuseppe Ricciardi and Na-Young Ryu.

References

- Nicholas Asher and Brian Reese. 2007. Intonation and discourse: Biased questions. In S. Ishihara, S. Jannedy, and A. Schwarz, editors, *Working Papers of the SFB632, Interdisciplinary Studies on Information Structure (ISIS)*, volume 8, pages 1–38. Universitätsverlag Potsdam, Potsdam.
- Atissa Banuazizi and Cassandre Creswell. 1999. Is that a real question? Final rises, final falls and discourse function in yes-no question intonation. In *CLS 35*, pages 1–14.
- Ellen Breitholtz and Robin Cooper. 2011. Enthymemes as rhetorical resources. In *SemDial: Proceedings of the 15th Workshop on the Semantics and Pragmatics of Dialogue*, pages 149–157.
- Ellen Breitholtz. 2014. *Enthymemes in Dialogue*. Ph.D. thesis, University of Gothenburg.
- Daniel Büring. 2012. Light negation and conventional implicatures. Slides presented at Information, discourse structure and levels of meaning, Barcelona.
- Ivano Caponigro and Jon Sprouse. 2007. Rhetorical questions as questions. In E. Puig-Waldmüller, editor, *Proceedings of Sinn und Bedeutung*, pages 121–133, Barcelona. Universitat Pompeu Fabra.
- Lawrence Yam-Leung Cheung. 2008. *The negative wh-construction*. Ph.D. thesis, UCLA.
- Lawrence Yam-Leung Cheung. 2009. Negative *wh*-construction and its semantic properties. *Journal of East Asian Linguistics*, 18:297–321.
- Herbert H. Clark, editor. 1996. *Using Language*. Cambridge University Press, Cambridge.
- Donka F. Farkas and Kim B. Bruce. 2010. On Reacting to Assertions and Polar Questions. *Journal of Semantics*, 27:81–118.
- Donka F. Farkas and Floris Roelofsen. 2017. Division of Labor in the Interpretation of Declaratives and Interrogatives. *Journal of Semantics*, 34:237–289.
- Jonathan Ginzburg. 1997. Structural mismatch in dialogue. In Anton Benz and Gerhard Jäger, editors, *Munich Workshop on Formal Semantics and Pragmatics of Dialogue. Proceedings*, pages 59–80, Munich. University of Munich.
- Jonathan Ginzburg. 2012. *The Interactive Stance*. Oxford University Press, Oxford.
- Christine Gunlogson. 2001. *True to Form: Rising and Falling Declaratives as Questions in English*. Ph.D. thesis, University of California Santa Cruz.
- Laurence R. Horn. 1985. Metalinguistic Negation and Pragmatic Ambiguity. *Language*, 61:121–174.
- Manfred Krifka. 2008. Basic notions of information structure. *Acta Linguistica Hungarica*, 55:243–276.
- Manfred Krifka. 2017. Negated polarity questions as denegations of assertions. In Chungmin Lee, Ferenc Kiefer, and Manfred Krifka, editors, *Contrastiveness in Information Structure, Alternatives and Scalar Implicatures*, pages 359–398. Springer.
- Janet Pierrehumbert and Julia Hirschberg. 1990. The meaning of intonational contours in discourse. In Philip R. Cohen, Jerry Morgan, and Martha E. Pollock, editors, *Intentions in Communication*, pages 271–312. MIT Press, Cambridge, MA.
- Kyle Rawlins. 2010. Conversational backoff. In *Proceedings of SALT 20*, pages 347–365.
- Craige Roberts. 2012. Information structure in discourse: Towards an integrated formal theory of pragmatics. *Semantics & Pragmatics*, 5:1–69.
- Maribel Romero and Chung-Hye Han. 2004. On negative *yes/no* questions. *Linguistics and Philosophy*, 27:609–658.
- Julian Schlöder, Ellen Breitholtz, and Raquel Fernández. 2016. Why? In Julie Hunter, Mandy Simons, and Matthew Stone, editors, *SemDial 2016 Proceedings of the 20th Workshop on the Semantics and Pragmatics of Dialogue*, pages 5–14. Rutgers University, New Brunswick, NJ.